



SW机床在新能源汽车领域的解决方案

姚来顺

销售经理

13601256106

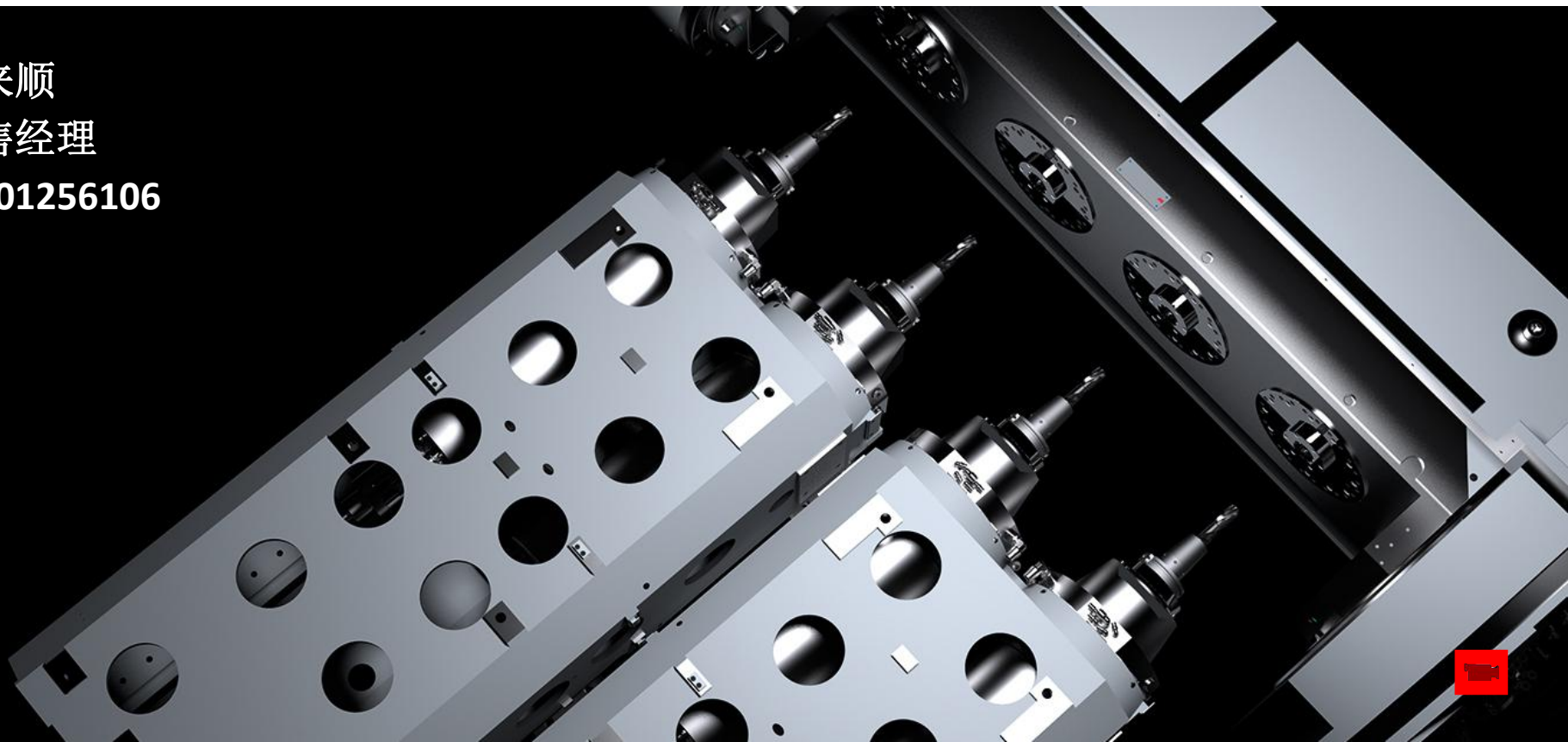

Contents

内容

AGENDA
议程

1 SW Company
SW 公司

2 SW machine advantages
SW 机床特点

3 SW machine models
SW 型号及分类

4 SW - know how for efficient
SW 高效

5 Metal cutting examples
机加案例

6 SW automation
SW 自动化

What is SW

什么是SW

- THE COMPANY
- 公司



1984 Tetra-Mill,
first mechanical
4 spindle machine
1984年，第一台
4主轴机床

1981-

Heckler & Koch
Maschinen- und
Anlagenbau/
Heckler & Koch

机械设备制造公司

1995

Restarted as
Schwäbische
Werkzeugmaschinen – SW / 更名为
德国埃斯维机床
– SW

2004 – 2008

SW owned by
EMAG
Maschinenfabrik/
SW由埃马克机床
控股

2008 – 2012

SW jointly owned
by SDB + EMAG/
SW由南德投资公司
和埃马克共同
控股

2010

SW - Shanghai
Representative
Office started/ 设
立SW上海代表
处

2012

SW成为独立公
司

2014

SW Asia Co., Ltd.
Registered
(WFOE)/

SW(苏州)埃斯维
机床(苏州)有限
公司

Development in China

中国发展历程

SW in China
SW 在中国

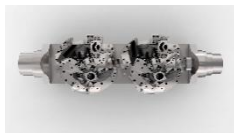

2010

Standard machine
单机交钥匙

2016

Customizing machine
单机+自动化交钥匙

2017

Production line
整套智能生产系统交钥匙

2010

Open Shanghai representative office
成立上海代表处

2014

SW Suzhou registered
sw 苏州注册

2015

SW Suzhou founded
sw 苏州奠基

2016

SW Suzhou opening
sw 苏州开业

2017

SW Beijing office opening
sw 北京办公室开业

2019

SW CQ opening
sw 重庆开业

2020

Sign SW Suzhou II land contract
sw 苏州签署二期土地合同



SW Global SW 全球



€ 250
MILLION
2.5亿欧元

In 2020
revenue

1105
EMPLOYEES
1105名员工
Across the world
till 2020



SW Global
SW 全球

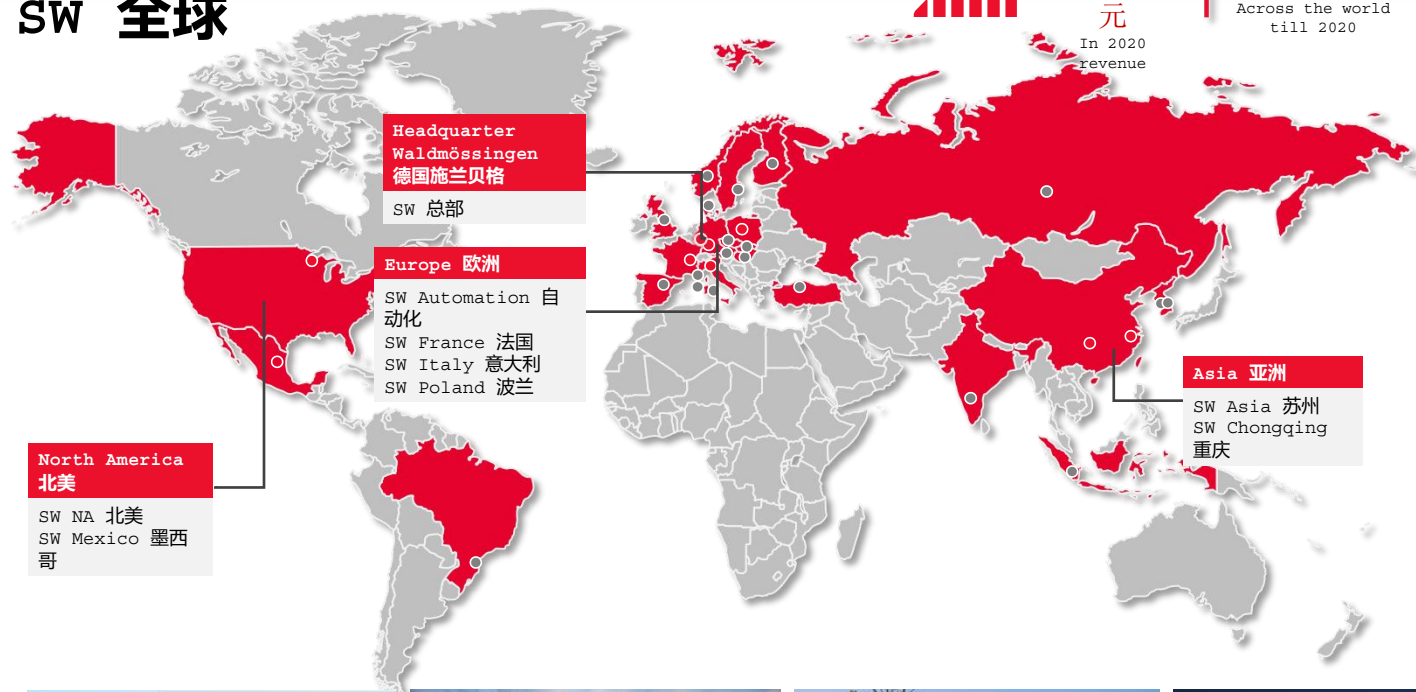

- Headquarter and subsidiaries
总部及子公司
- Sales partner
销售代表





SW Asia
SW中国

SW Asia
SW 中国



SW Global Order income (Distributed by countries)

SW全球订单额 (按国家分布)

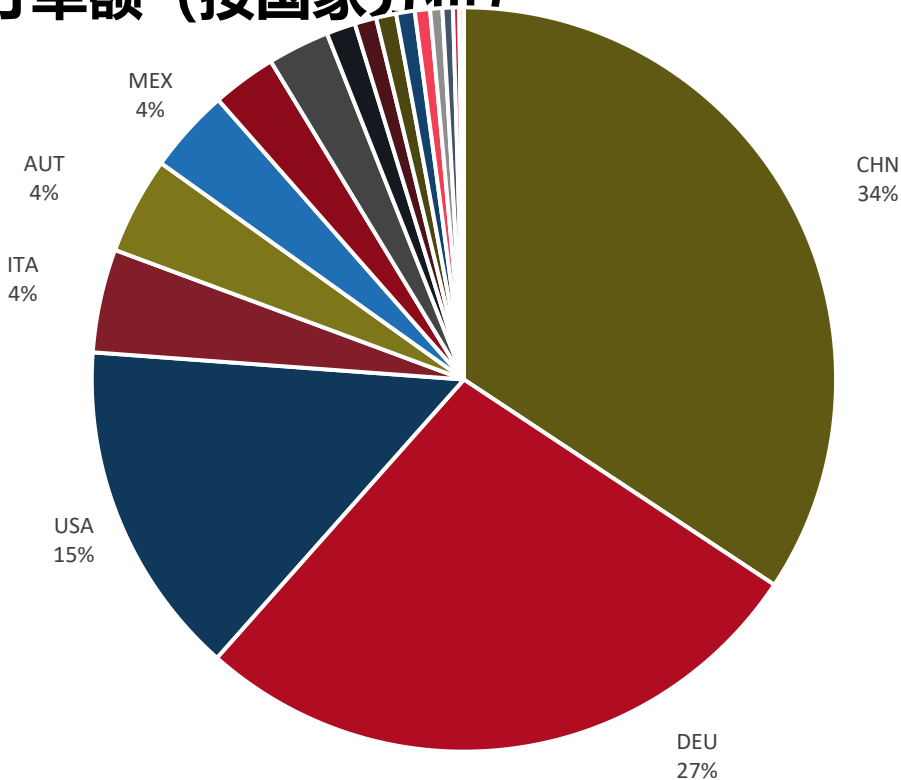

SW Global
SW 全球

SW Technology SW技术

SW Global
SW 全球



Machining 加工

Multispindle Machines: High Efficiency / Precision / Speed
多主轴加工中心

Applications: Sophisticated / Experienced Turnkeys
加工解决方案



Systems 生产系统

Production Cells
With integrated Automation
生产单元系统

Production lines:
Integrated / Modular / Versatile
生产线系统

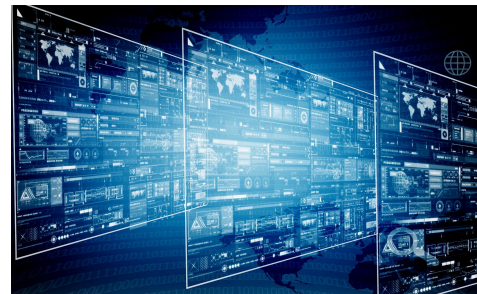

Digitization 数字化

Advanced Online Services: Monitoring / Predictive Maintenance
在线服务

Plant Simulation / Traceability / Manufacturing Analysis (MES)
工厂模拟

Customer structure

客户组成

THE COMPANY/
公司



Main customers 主要客户



Main customers
主要客户



3 SW machine models

SW 型号及分类

3 SW machine models

BA	4	2	2
滚珠丝杠机型	主轴间距 mm	主轴数量	工作台数量

- 切削磁性和非磁性
- 高扭矩重切削
- X, Y和Z-axis滚珠丝杠

BA W0	4	—	2	2
直线电机机型	主轴间距 mm		主轴数量	工作台数量

- 非磁性
- 大动力，高加速度，高速度
- 高精度保持性

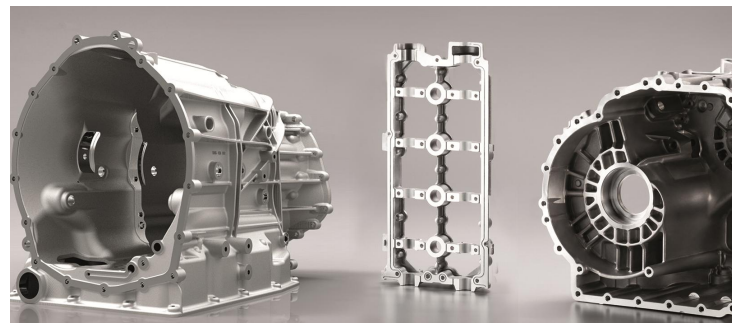

3 SW machine models

SW 型号及分类

- **Ball screw machines 滚珠丝杠机型**

3 SW machine
models

VIDEO

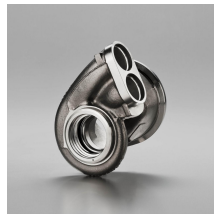

3 SW machine models SW 型号及分类

- **Linear Motor machines** 直线电机机型

3 SW machine models

VIDEO



BA one6



BA one8



BA W02-22



BA W04-x2



BA W06-x2

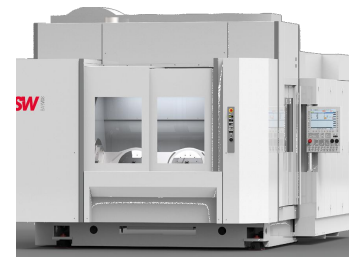

BA W08

小small ← → 大big

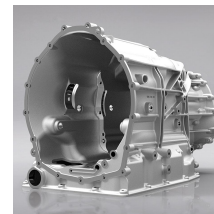

4 SW - know how for efficient

SW 高效

效率/Efficient



节拍=加工总时间 ÷ 工件数量

100%

4 SW - know how for efficient
SW 高效

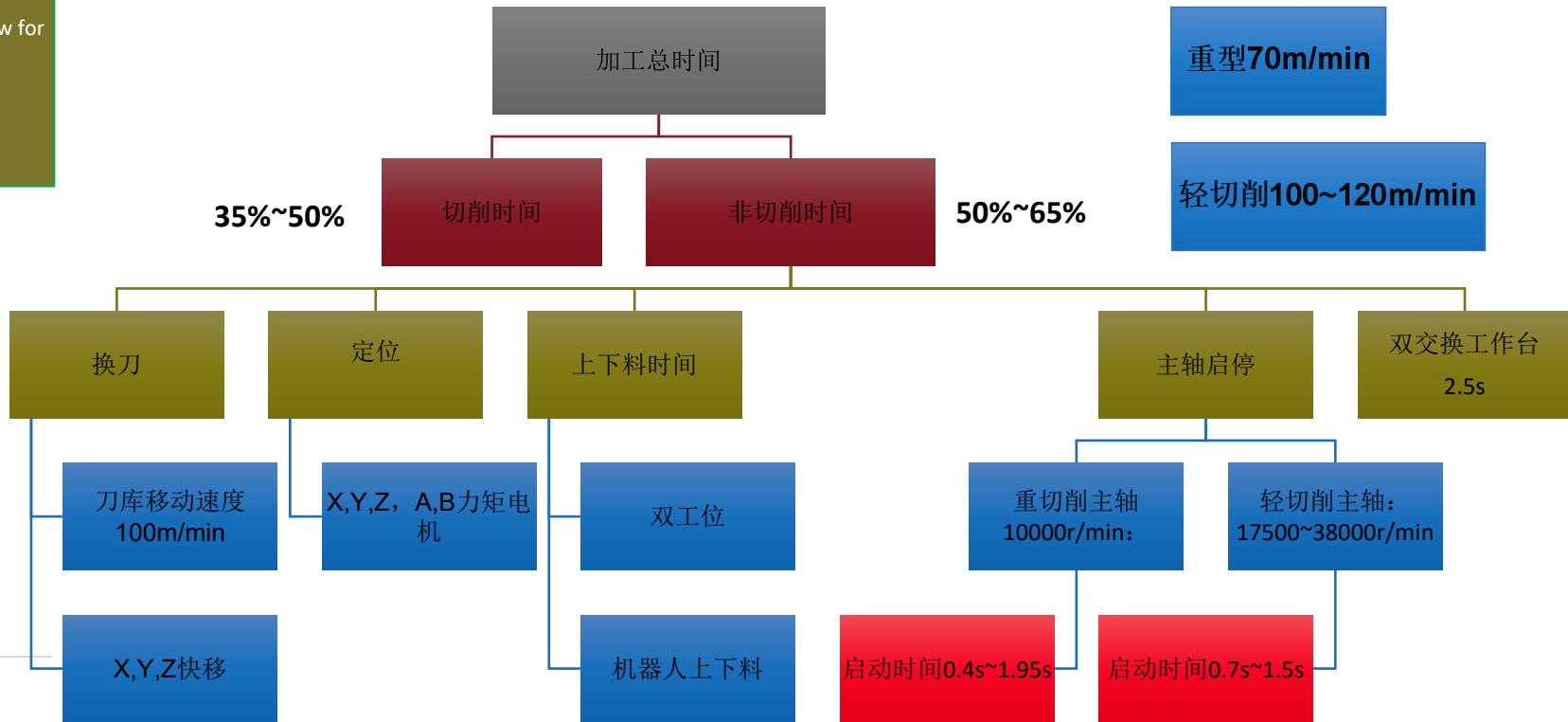

高效 Efficient

3 SW - know how for efficient
SW 高效

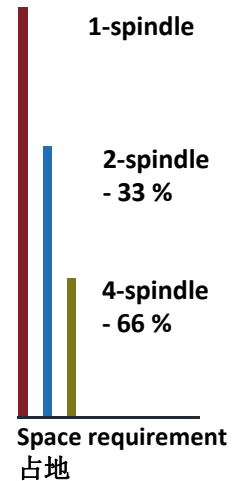
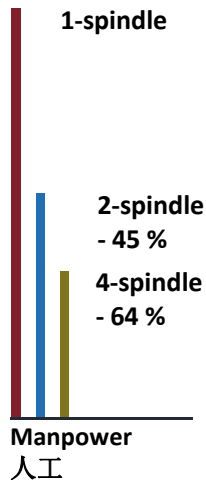
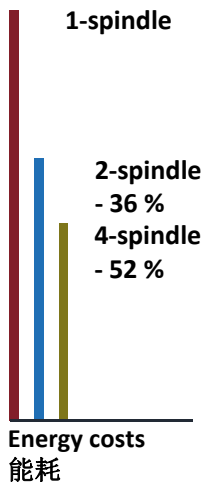

Example 案例1



	投资	SW	通用单轴加工中心
	节拍	95.8 秒/件	400秒/件
	设备台数	$95.8 \div 20 = 4.8$ 台	$400 \div 20 = 20$ 台
	设备投资	$5 * \text{BAW 06-22} = ?$	$400\text{万/台} * 20\text{台} = 8000\text{万}$
	总投资	?万	8000万
使用成本	占地	150平米	600平米
	人员	1	4?
	能源消耗	5台+5台自动化	20台+20台自动化

新能源汽车部件

TECHNOLOGY
MACHINES
SYSTEMS

NEV
New Energy Vehicle

BEV
Battery Electric Vehicle

PHEV
Plug-in Hybrid Electric Vehicle

FCEV
Fuel Cell Electric Vehicle

1 Power Motor
电驱系统

2 Battery
电池系统

3 Suspension
悬架系统

4 Frame part
大型结构件

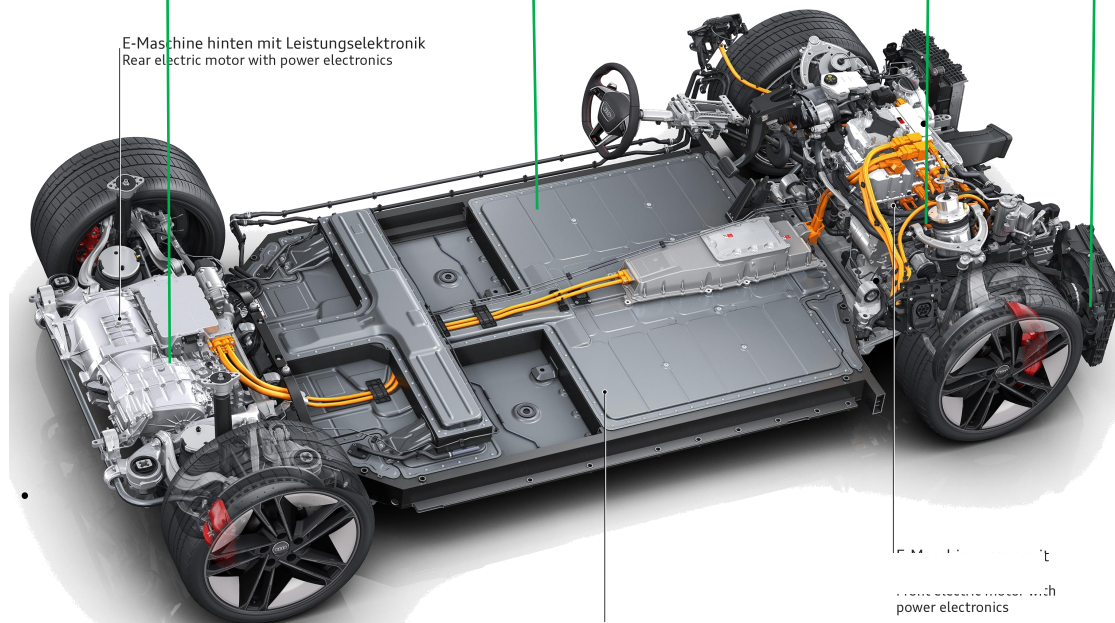

E-Maschine hinten mit Leistungselektronik
Rear electric motor with power electronics

E-Maschine hinten mit Leistungselektronik
Rear electric motor with power electronics

1 Power Motor 电驱系统 电机壳_E-Housing

TECHNOLOGY
MACHINES
SYSTEMS

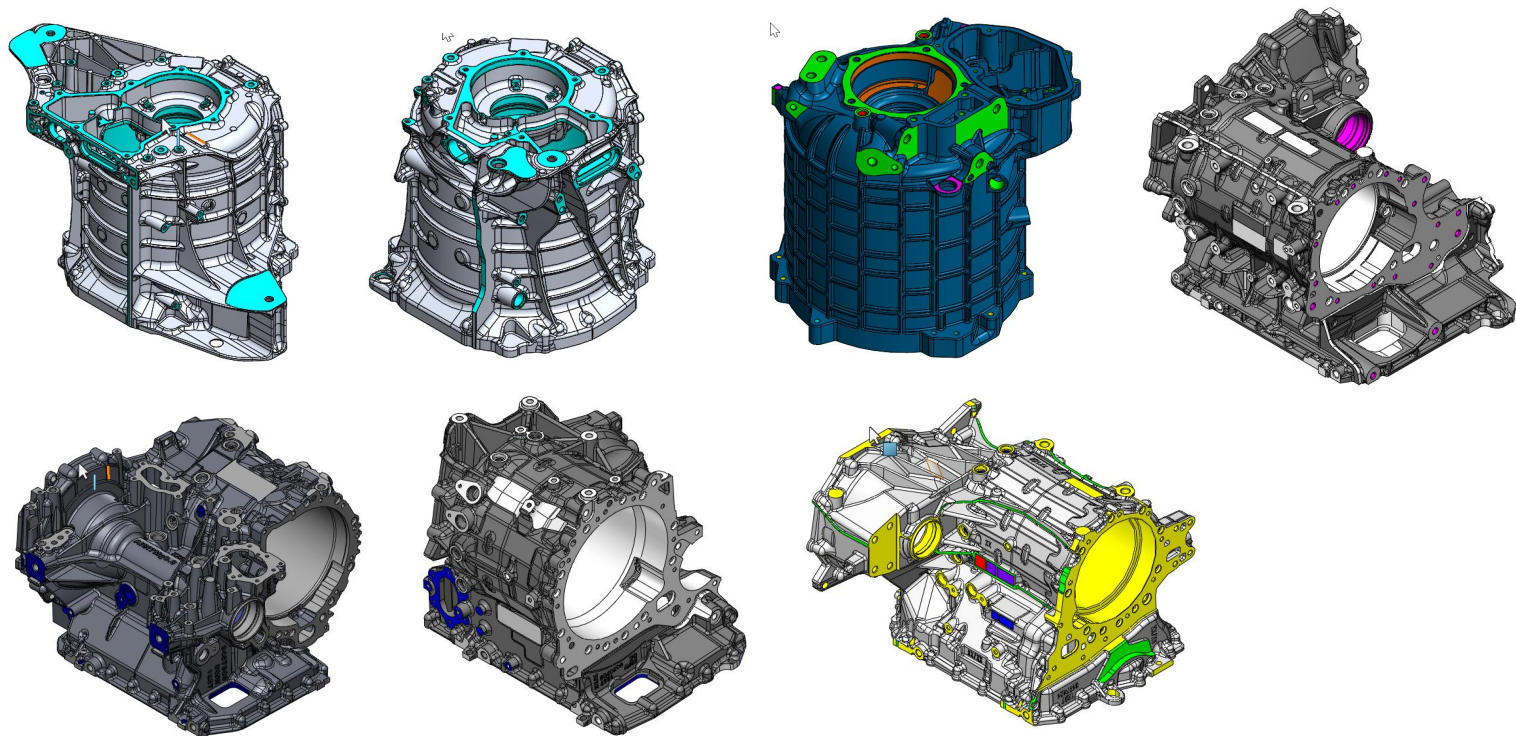

1 Power Motor电驱系统 电机壳_E-Housing

TECHNOLOGY
MACHINES
SYSTEMS

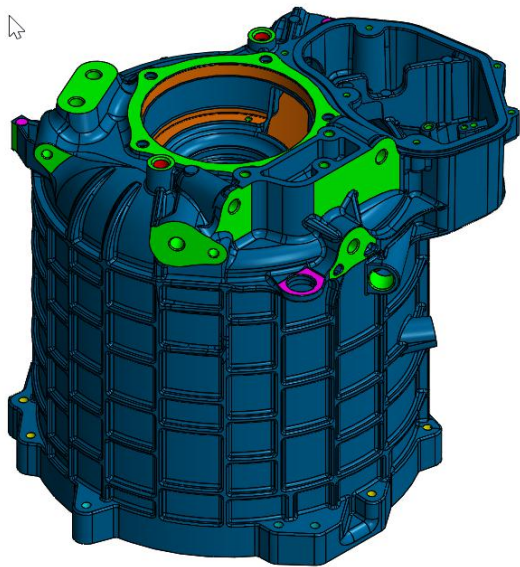

== 200,000件/年
1.6分钟/件

- Workpiece: E-motor housing
- Material: EN 1706 AC-47100/1.4021

年工作时间=300天*21小时*85%开动率=5355小时=321300分钟

1 Power Motor 电驱系统 电机壳_E-Housing

KEY FACTS



- BA W06-21&22(HSK63A&100A)
- 600mm~650mm
- BA 622-HSK100A
- 600mm~650mm

1 Power Motor 电驱系统 电机壳_E-Housing

TECHNOLOGY
MACHINES
SYSTEMS

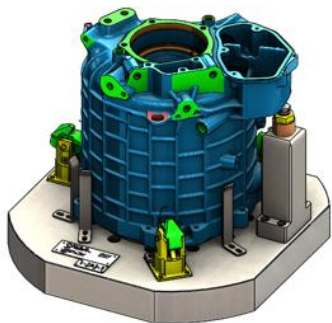

- 2 nests on 5 axis fixture

OP10=6.6分钟/2件=3.3分钟/件

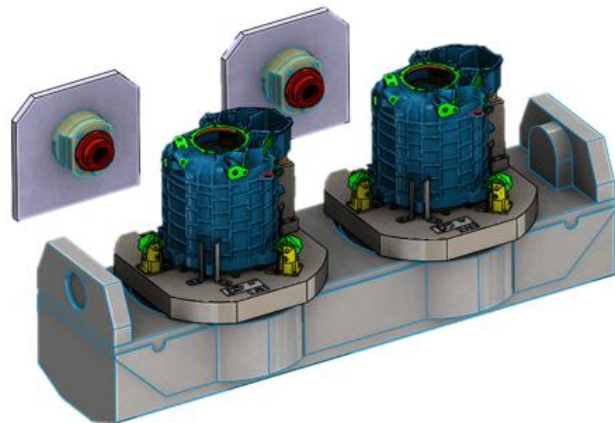
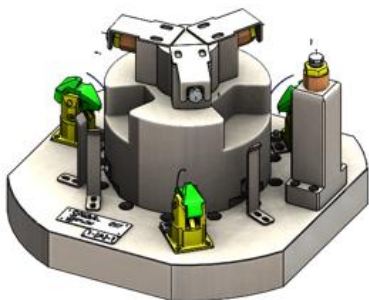

1 Power Motor 电驱系统

电机壳_E-Housing

TECHNOLOGY
MACHINES
SYSTEMS

Clamping Fixture – OP20

- 2 nests on 4 axis fixture

OP20=6.5分钟/2件=3.25分钟/件

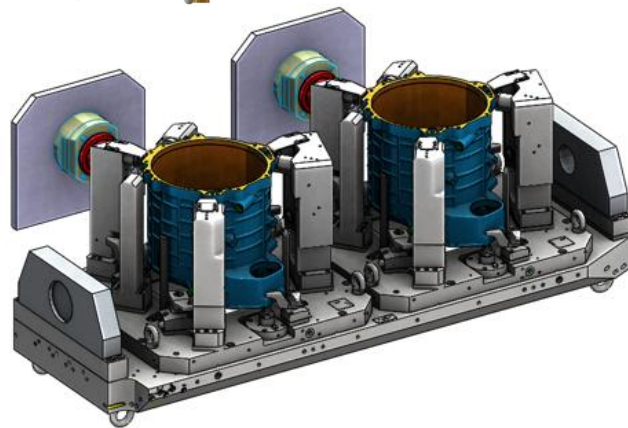
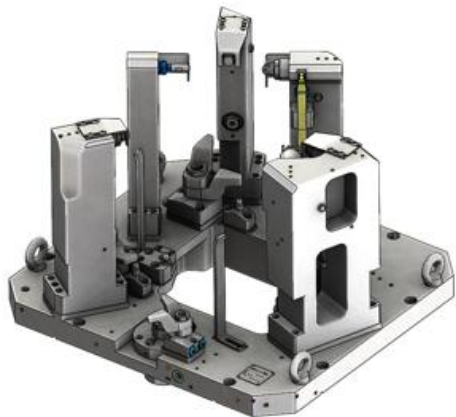
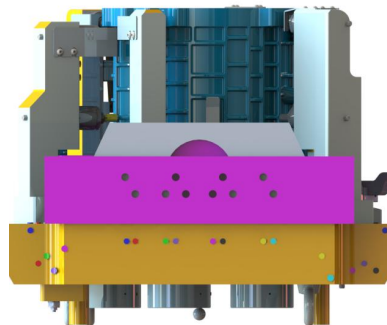
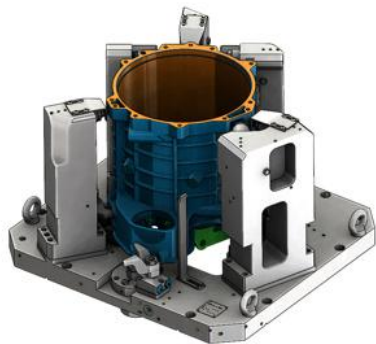

1 Power Motor 电驱系统 电机壳_E-Housing

TECHNOLOGY
MACHINES
SYSTEMS

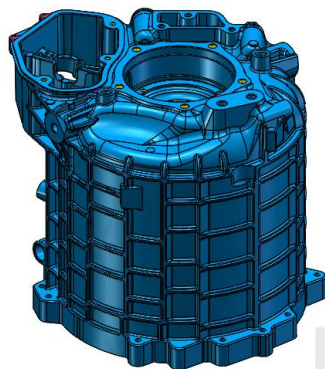
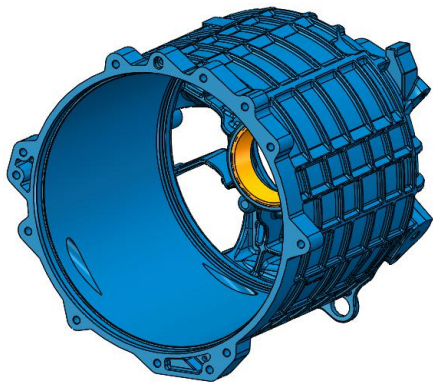

2 Battery 电池 电池壳_Battery case

- 混动新能源汽车



- 电动新能源汽车

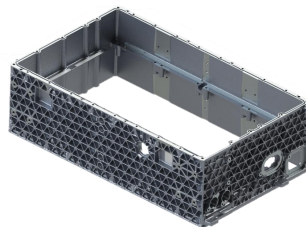

2 Battery 电池 电池壳_Battery case

TECHNOLOGY
MACHINES
SYSTEMS

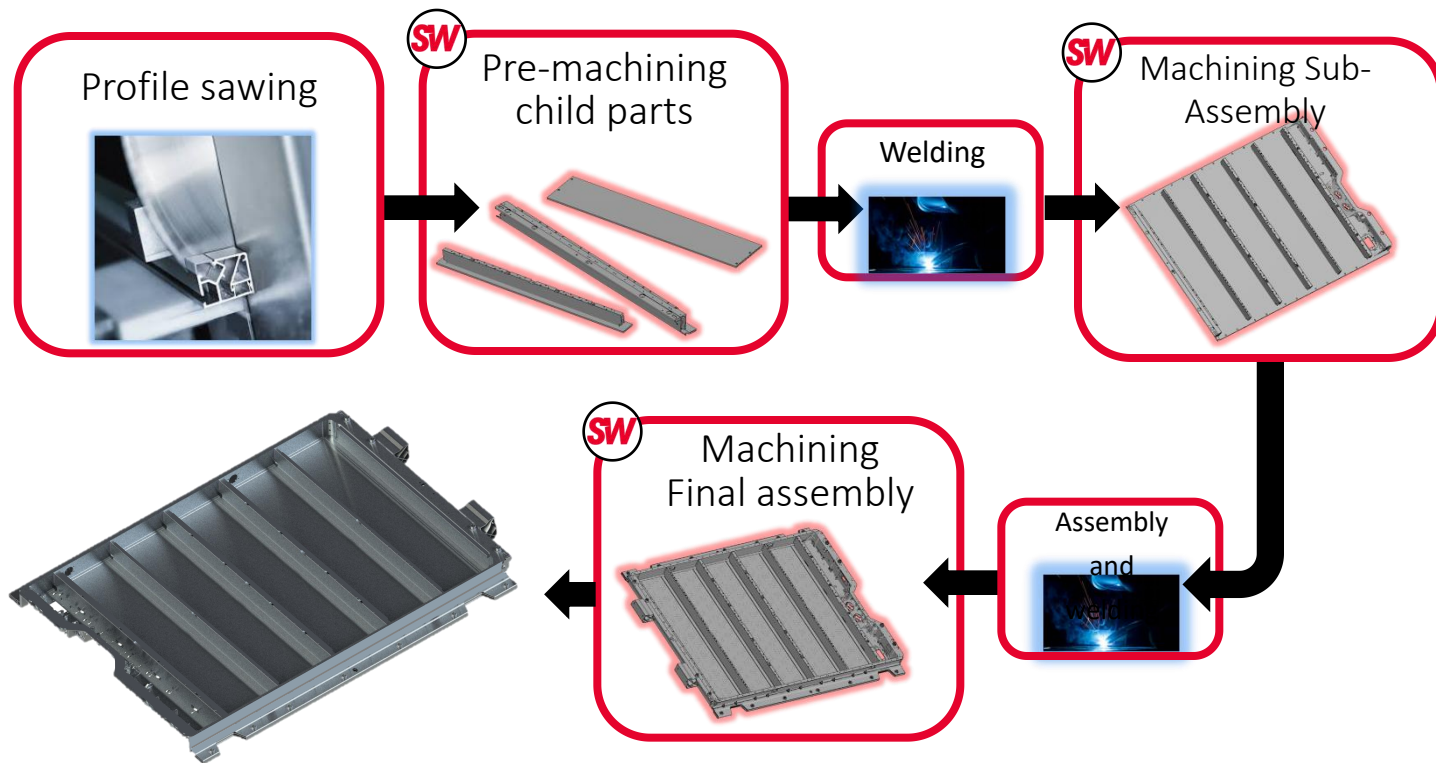

2 Battery 电池 电池壳_Battery case

TECHNOLOGY
MACHINES
SYSTEMS



SW BA 3



SW W06

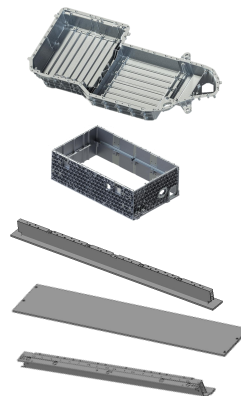

SW W08



SW Space3

BA space3

Maschine Data

2 Battery 电池 电池壳_Battery case

DETAILS

Transport (H x W x D)

5.8m x 3.7m x 4.1m

Dimensions (H x W x D)

8.2 m x 4.8m x 6.6m

Weight

27,000 kg



Machine footprint

25.3 m²

Connection / total output

3x400 V, 50 Hz / 105 kVA

CNC –control

Sinumerik 840 D sl

BA space3

Q-Achse - Werkstückaufnahme

2 Battery 电池 电池壳_Battery case

DETAILS

Aufspannfläche
3.000mm x 1.640mm

Befestigungsraaster
58 x M12 (300x120mm)

Medienzufuhr
16 Verteilerspuren
250 bar Hydraulik
8 bar Pneumatik

Max. Traglast
2 x 1.000kg



Schwenkbereich
358°
0° auf 180° in 4s

Antrieb - Servomotor
16 min⁻¹, 3.000 Nm

2 Battery 电池 电池壳_Battery case

核算一览表 - 机床数量

TECHNOLOGY
MACHINES
SYSTEMS

SCENARIO 1 w/o flexibility = 26.7 Jobs per hour				
Machining centers needed				
phase	SW BA W08-12	SW BA Space3	Σ	
Child parts	4 x	2 x	6 x	
Sub assembly	-	8 x	8 x	
Final assembly	-	4 x	4 x	
	Σ:	4 x	14 x	18 x
SCENARIO 2 w/flexibility = 30.5 Jobs per hour				
Machining centers needed				
phase	SW BA W08-12	SW BA Space3	Σ	
Child parts	6 x	2 x	8 x	
Sub assembly	-	9 x	9 x	
Final assembly	-	5 x	5 x	
	Σ:	6 x	16 x	22 x

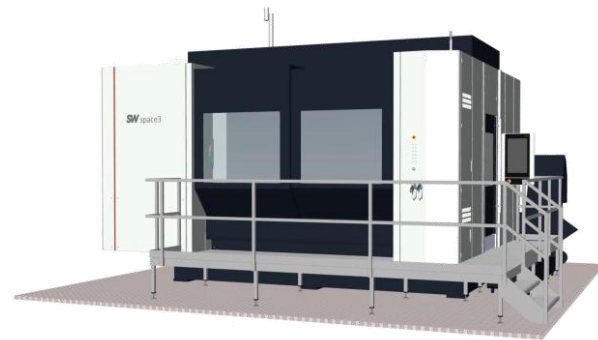
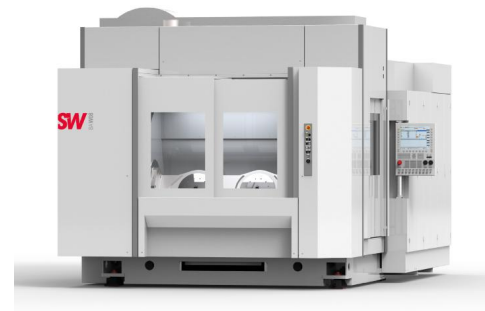

2 Battery 电池

电池壳_Battery case

设备 #15+#16 – BA space3 – 最终装配 OP10

TECHNOLOGY
MACHINES
SYSTEMS

30 Final assembly SW BA Space3

part	platform	pc/platform	finish pc/fixture/spindle	comments	cycle time [s]	technical availability [%]	pc/hr	scenario 1, machines needed	scenario 2, machines needed	scenario 1	scenario 2
Final assembly EB40 OP10	EB40	1	2		341,22	95%	20,05	0,18	0,21		
Final assembly EB42 OP10	EB42	1	2		374,66	95%	18,26	1,26	1,44		
Machines needed:								1,44	1,65	2 x	2 x
Fixtures needed:										2 x	2 x

fixture concept:

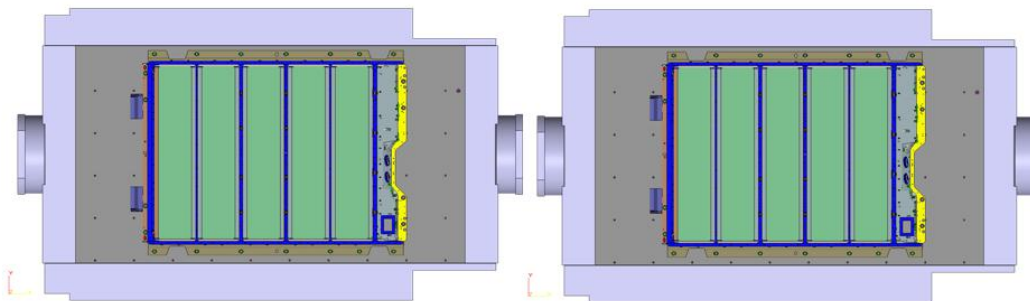

→ 部件的运输和加工零部件的上下料采用自动化系统

3 Suspension 悬架系统 副车架-Sub frame

TECHNOLOGY
MACHINES
SYSTEMS

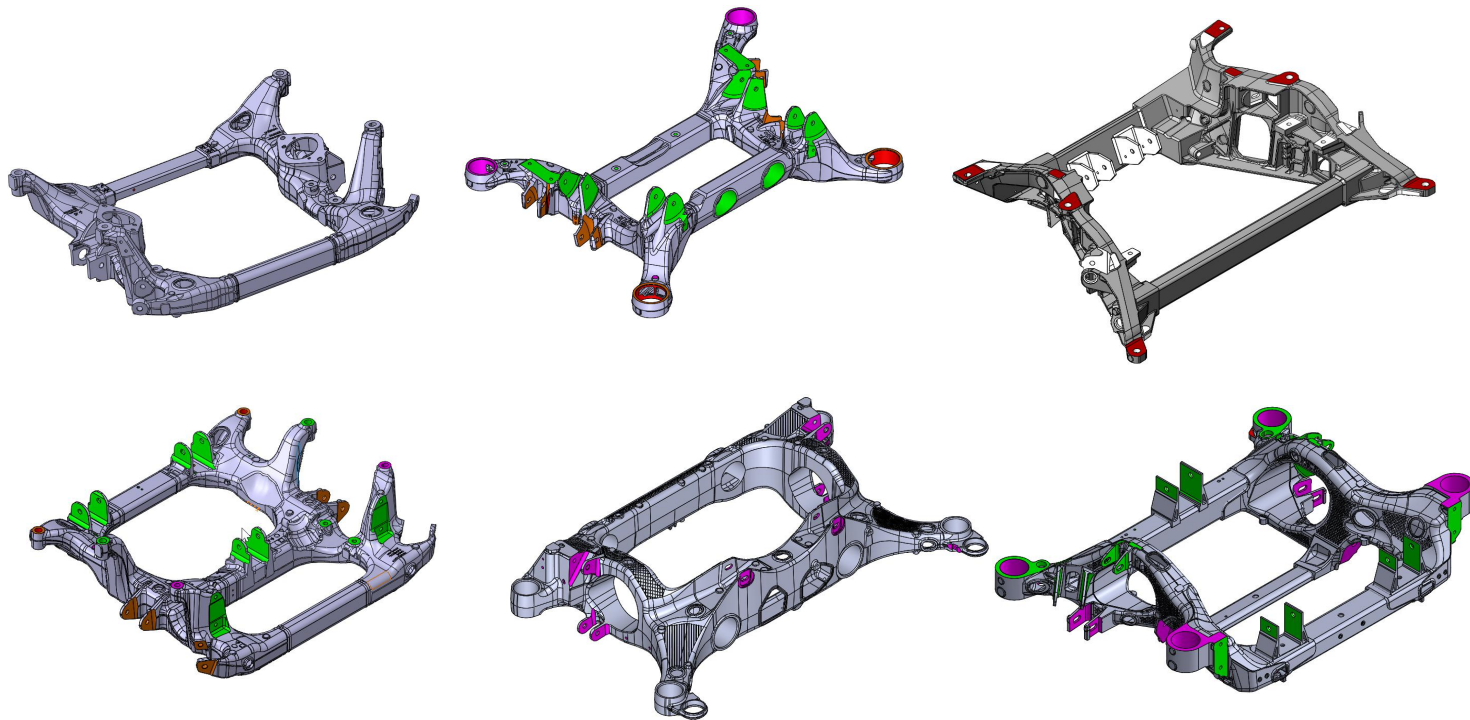



BA W08-11&21

1000mm~2000mm

3 Suspension 悬架系统 副车架-Sub frame

TECHNOLOGY
MACHINES
SYSTEMS



3 Suspension 悬架系统 副车架-Sub frame

WORKPIECES

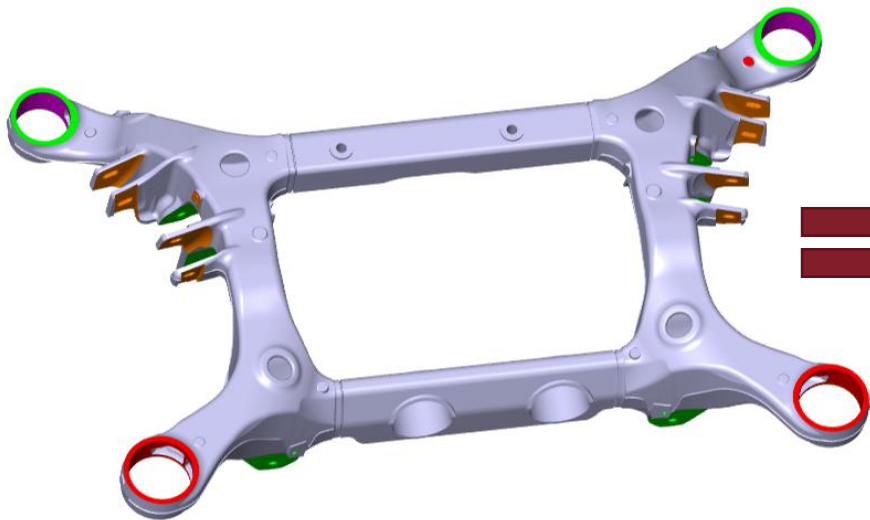

— **120,000件/年**
2.68分钟/件

年工作时间=300天*21小时*85%开动率=5355小时=321300分钟

3 Suspension 悬架系统 副车架-Sub frame

OP10=6.2分钟/件

2台SW机床

OP10+OP20=1件=6.2分钟

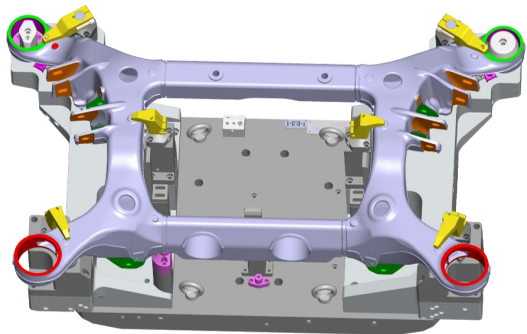
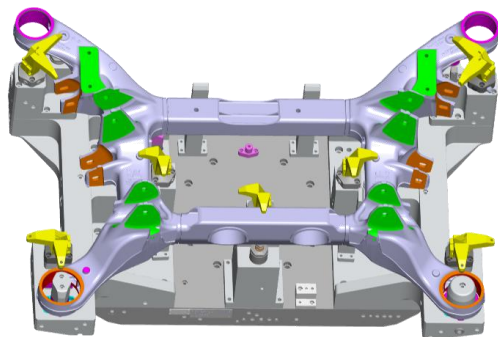

OP20=6.1分钟/件



2*BAW 08-11



3 Suspension 悬架系统 副车架-Sub frame



Examples
案例

	投资	SW	通用单轴加工中心
	节拍	6.2分钟/件	30分钟/件
	设备台数	$6.2 \div 2.68 = 4.63$ 台	$30 \div 2.68 = 11.19$ 台
		1台	=2.42台
	设备投资	5*BAW 08-11=?	450万/台*11.19台=5000万
	总投资	?万	5000万+.....
使用成本	占地	$44.14 * 5 = 220.68$ 平米	350平米
	人员	1	6?
	能源消耗	5台+5台自动化	12台+12台自动化

4 Frame part大型结构件

PRODUCTS
产品

悬架支撑件

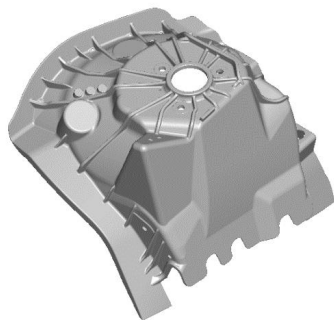

底盘结构件

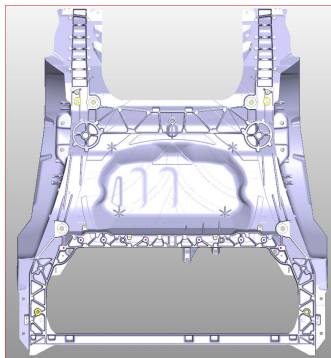

底盘结构件

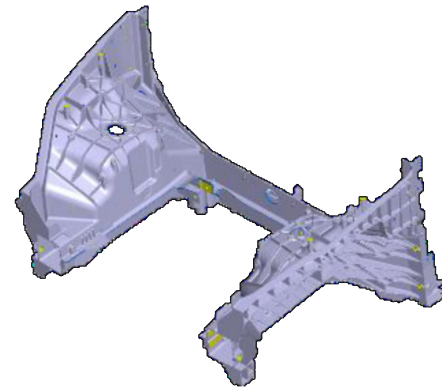

4 Frame part大型结构件

超大型铝合金—BA *space3*

2000mm~3000mm

PRODUCTS
产品



有以下产品请联系我们

我们的强项

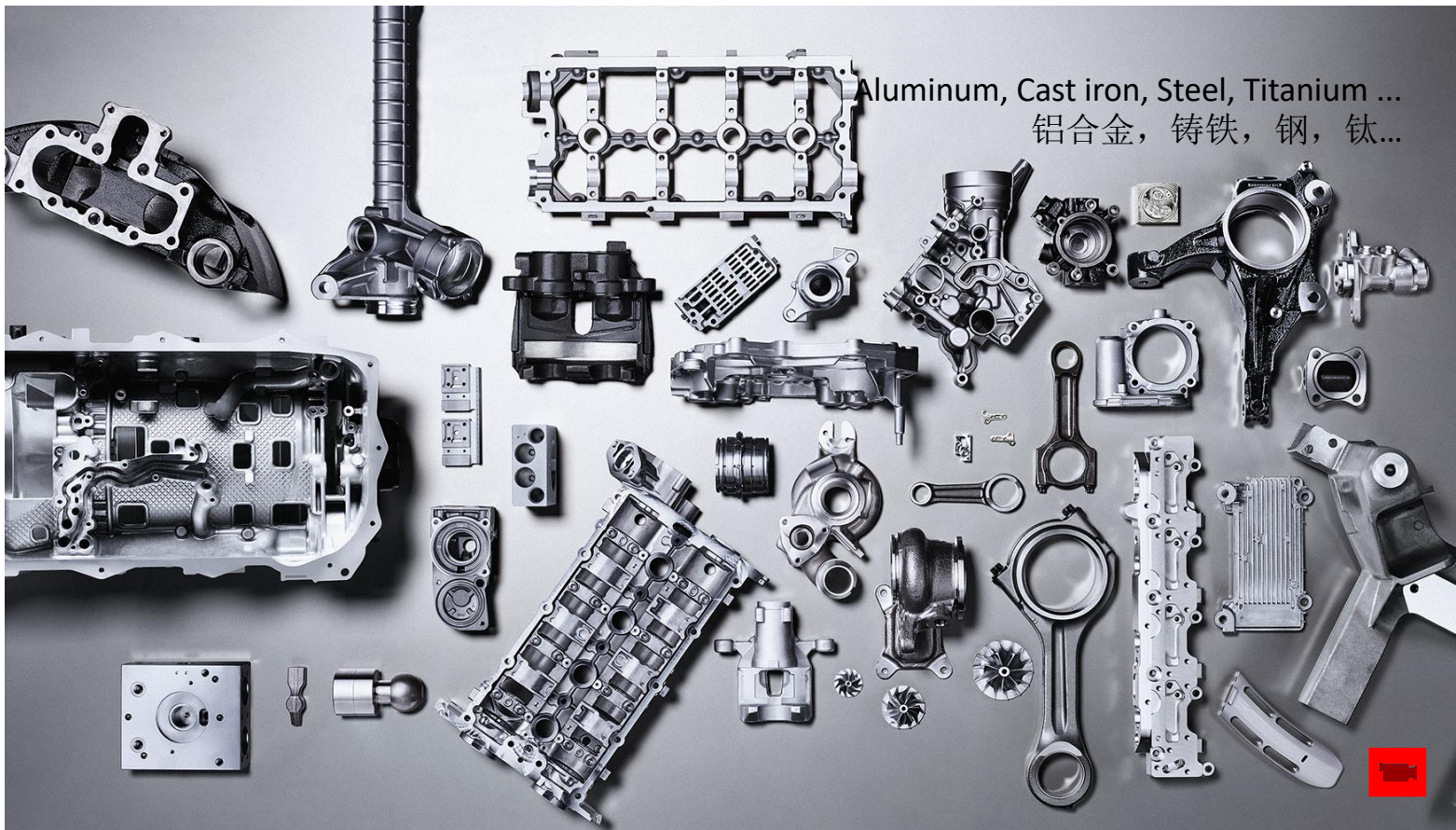

Aluminum, Cast iron, Steel, Titanium ...
铝合金, 铸铁, 钢, 钛...





SW Asia
SW 中国



SW 微信公众号



SW公司二维码