

SHANTUI

PRESENTATION



Shandong Shantui Machinery Co., Ltd.

1. Company Profile
2. General Overview of Shantui Forklift
3. Introduction to Shantui Group
4. Shantui Forklift Overseas Market Development



Company Profile



SHANTUI



- ❖ With Group company's strategic planning, Shandong Shantui Machinery Co., Ltd. was founded in 2010 in Jining, China. It mainly develops & manufactures 1.5-25 tons diesel, gasoline, LPG & electric forklifts. Also it manufactures rotary drilling rigs & various construction machinery components.
- ❖ Shantui Heavy Industry Park occupies an area of 350,000 square meters. It has an annual capacity of 30,000 forklifts and 100 rotary drilling rigs.

Responsibility Communication Inclusiveness





Vision & Mission

- Market Globalization
- Localized Manufacturing
- R & D Internationalization

We're dedicated to excellent equipment R&D, manufacturing, distribution & service.

By the scheduled long-term strategic planning, we are ambitious to become a top player in forklift & pile driver fields domestically & internationally with sustainable development.



Corporate Advantages

- With Shantui Group's more than 30 years cooperation with Komatsu, Shantui Machinery inherits advanced manufacturing technology, strict engineering standard & rich managerial experience.
- Shantui Machinery strengthens its efforts in introducing various experts & talents in its field in recent years. Up to now, Shantui Machinery already has one of the biggest Forklift R&D Institutes in China with over 200 experts & engineers working there. Also Shantui Machinery establishes a close cooperative relationship with many famous universities to consolidate its intellect basis.
- Shantui Machinery pays great attention to the training of every staff. Shantui Technical School trains excellent & loyal blue workers. High quality employees finally result in high quality products.



SHANTUI

- To manufacture reliable products, Shantui Machinery is paying efforts to build an effective strategic sourcing & purchasing network. We deeply understand the importance for sub-suppliers & their spare parts to the quality of final products.
- Shantui Machinery is a customer & market driven company. It's a long tradition to offer good pre & after-sales services to customers. We offer our sincere service anytime and anywhere.



Responsibility Communication Inclusiveness

General Overview of Shantui Forklift



SHANTUI

SHANTUI manufactures 1.5-10 & 20-25 tons diesel, gasoline & LPG forklifts with world resounding Isuzu/Yanmar/Nissan/Perkins/Volvo engines. It also manufactures AC/DC 1.5-3 tons electric forklifts with Zapi or Curtis controller.

In 2012, SHANTUI will further diversify its product range. Shantui Forklift Research Institute is developing 3.5-ton electric forklift, 7-ton forklift specially for stone industry, 12-18 tons forklift, side loader & I.C. traction truck. By the schedule, the development work will be finished this year totally.

SHANTUI has a plan to develop container handler & reach stacker up to 46 tons in the nearest future.

Responsibility Communication Inclusiveness



SHANTUI

1.5-2.5T I.C. Forklift



CAPACITY		1.5T/1.8T/2T/2.5T				
		Diesel			Gasoline	
ENGINE	Brand	YANMAR	ISUZU	ISUZU	NISSAN	NISSAN
	Model	4TNE92	4JG2	C240	K21	K25

Responsibility Communication Inclusiveness



SHANTUI

3-3.8T I.C. Forklift



CAPACITY		3T/3.5T/3.8T			
		Diesel		Gasoline	
ENGINE	Brand	YANMAR	ISUZU	ISUZU	NISSAN
	Model	4TNE98	4JG2	C240	K25

Responsibility Communication Inclusiveness



SHANTUI

4-5T I.C. Forklift



CAPACITY		4T/4.5T			5T
		Diesel			Diesel
ENGINE	Brand	YANMAR	PERKINS	CHINA ISUZU	PERKINS
	Model	4TNE98	1104D	JX493G	1104D-44

Responsibility Communication Inclusiveness



SHANTUI

5-10T Diesel Forklift



CAPACITY		6T		7T		10T		
		Diesel		Diesel		Diesel		
ENGINE	Brand	PERKINS	ISUZU	PERKINS	ISUZU	ISUZU	PERKINS	CHAOCHAI
	Model	1104D-44TA OR 1106D	6BG1	1104D-44TA OR 1106D	6BG1	6BG1	1106D	6102BG



Responsibility Communication Inclusiveness

Technical Features of Shantui I.C. Forklift

- **Man-machine Harmony Ergonomic Design**
Shantui engineers adopt built-in tilt cylinder and adjustable shock-absorbing seat to reduce drivers' fatigue maximumly. Also the wide-vision mast provides excellent operational vision.
- **Shock-absorbing Design**
Shantui adopts floating overhead guard & shock-absorbing steering axle to reduce 30% vibration to enhance the drivers' operational comfortability.
- **Robust Transmission Components**
High quality transmission components match hydraulic system effectively. The forklift becomes more efficient & energy-saving.
- **Dashboard & Wiring System**
Shantui adopts reliable electronic monitored combination dashboard with LCD & waterproof inserting structured wiring system to enhance safety & reliability.



SHANTUI

3T/3.5T Forklift(New Model)

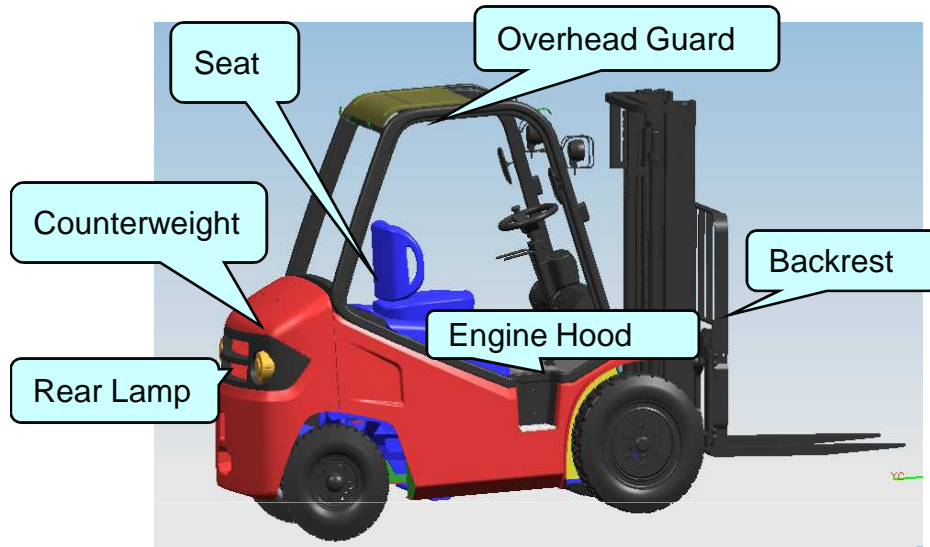

STREAMLINED
ALL NEW DESIGN

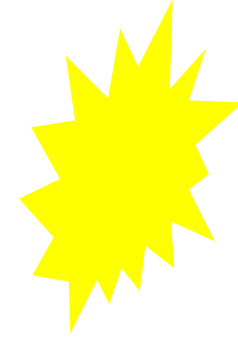

Feature:

1. High quality engine with electronic choke valve
2. With automatic electronic shifting transmission
3. Structural advanced braking device & parking brake safety warning device
4. New floating shock absorbing structure
5. New engine hood opening design
6. Lifting cylinder with buffering function
7. All new appearance



Responsibility Communication Inclusiveness

SHANTUI

20T/25T Heavy Duty Forklift



SF200/255 diesel counterbalanced forklift is widely used in ports, docks, steel mills, stock yards, airports, underground mining areas, logistic parks, etc. It's powerful & efficient for transporting & loading heavy items & containers between short distances.

Responsibility Communication Inclusiveness



1 ENGINE

Swedish VOLVOTAD721VE Turbo Engine
All Electronic Controlled EFI Type
Air Intercooling Function

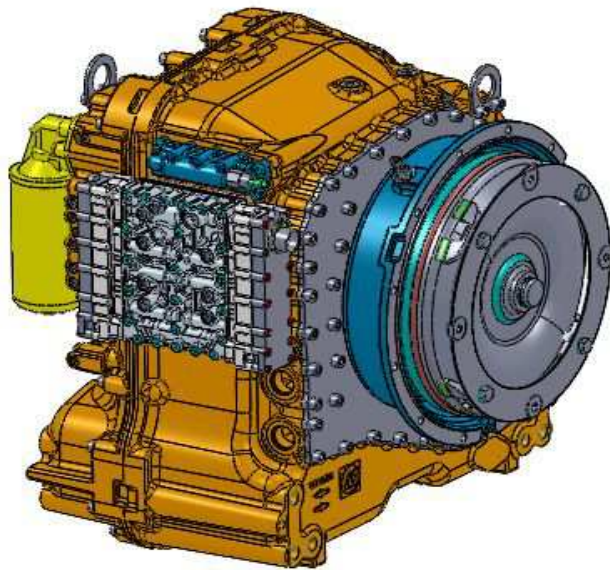

2 TRANSMISSION

- German 3WG211 Electro-hydraulic Controlled Transmission
- Power Severing Function to Facilitate Inching Control
- Obstacle Display to Facilitate & Simplify Maintenance



3 DRIVING AXLE



German KESSLER489 Heavy Duty Driving Axle

Maintenance Free Multi-plate Wet Brake with Automatic Abrasion Compensation Function

Safe & Reliable Parking Brake with Dry Central Caliper Disc Brake

4 HYDRAULIC BRAKING SYSTEM

Imported Highly Integrated & Energy Saving Hydraulic Components from PARKER, U.S.

Maintenance Friendly/Greater Braking Torque/Longer Life/ Robust & Anti-pollution



5 CABIN

Tilt Cabin Structure to Facilitate Maintenance

Cooler & Heater

Comfortable Operational Environment



6 WIRING

- Highly integrated & modularized relay control box design for the controlling part
- AMP insert with better dustproof & waterproof function
- Simplified design with safe & reliable function
- Many interfaces are reserved for further function expansion to reduce potential obstacle and enhance reliability



SHANTUI

3T Side Loader



The development of first Shantui side loader will be finished by middle 2012.



Responsibility Communication Inclusiveness



SHANTUI

1.5-3T Electric Counterbalanced Forklift

- ❖ There are two series: four-wheel & three-wheel types.
- ❖ For four-wheel electric forklift, there are three series: AC/DC/SEMI-AC.

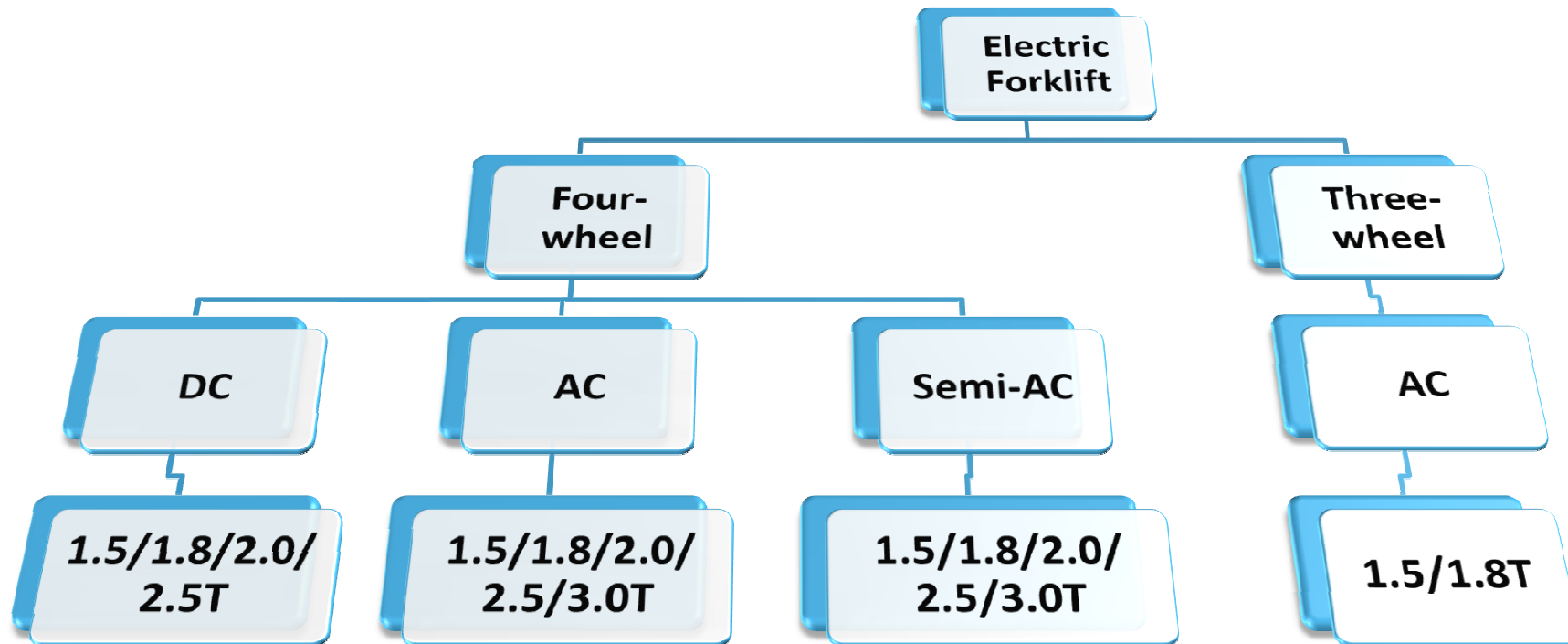

SHANTUI

1.5-2T Electric Forklift (Three Wheels)



Three wheels forklifts		
CAPACITY	1.5T	1.8T
	AC	AC



Responsibility Communication Inclusiveness

SHANTUI

1.5-3T Electric Forklift (Four Wheels)



CAPACITY	1.5T	1.8T	2T	2.5T	3.0T
DC Series	√	√	√	√	
Semi-AC Series	√	√	√	√	√
AC Series	√	√	√	√	√



Responsibility Communication Inclusiveness

Technical Features of SHANTUI Electric Forklift

1. Brushless & Maintenance Free Reliable AC Pedestrian Motor & AC Pump Motor
2. Excellent Low-speed Motor & Low noise Gear Pump without Steering Motor & Steering Oil Pump for Low Operational Noise Purpose
3. Advanced Controlling System with High Efficiency, Low Heat & Noise, Heat Protection Compensation & Over or Under Pressure Protection
4. Internationally Advanced CAN Wiring Technology to Ensure Communications Delivery Dependability & Economic Wiring Layout Design
5. Horizontally Placed Driving Motor & Reasonable Battery Location to Enhance Stability
6. Large-capacity Battery for Longer Working Hours
7. Interface Friendly Interactive Multi-function Liquid Crystal Display, with Sufficient Function & Password Setting Function



SHANTUI

2-6T Electric Traction Truck



	2T	3T	4T		5T		6T	
Capacity	AC Series	AC Series	DC Series	AC Series	DC Series	AC Series	AC Series	DC Series

Responsibility Communication Inclusiveness



SHANTUI

OPTIONS & ATTACHMENTS

To satisfy diversified requirements for various options & attachments, SHANTUI will always cooperates with all the clients to make SHANTUI forklift more powerful & comfortable.

We have side shift, German Grammar or Chinese Suspension Seat, FFL mast, solid tire, 2420mm fork, heater, cooler, cabin, paper roll clamp, load stabilizer, forging manipulator...



Responsibility Communication Inclusiveness

SHANTUI

Introduction to Shantui Group

Responsibility Communication Inclusiveness



Industry Status

Top 50 construction machinery manufacturers in the world (No. 22 in 2011)

Largest bulldozer manufacturer

70% market share in China
over one third market share in the world

Member of top 500 enterprises in China

Products cover more than 130 countries and regions



Product Categories

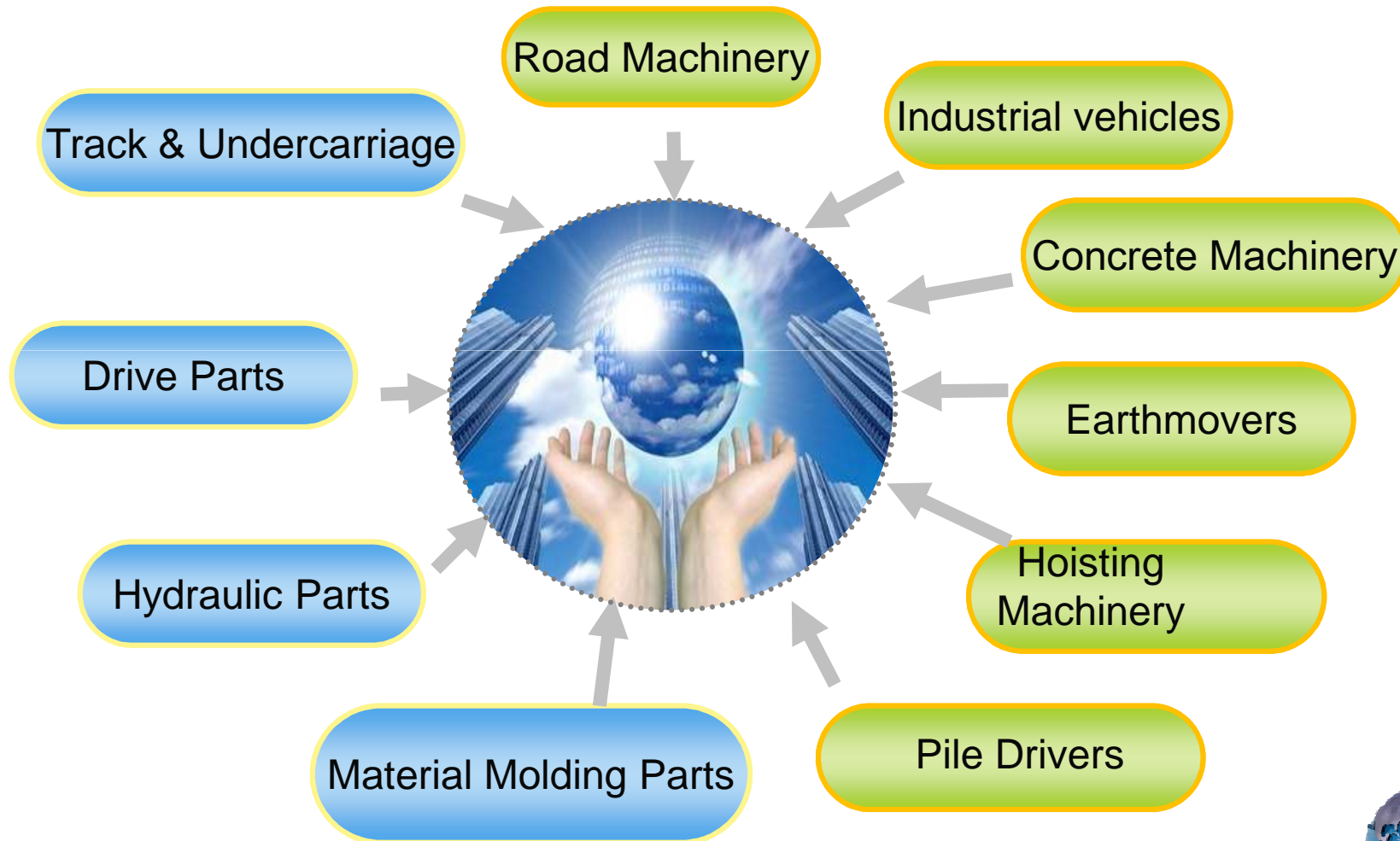

Rapid Development

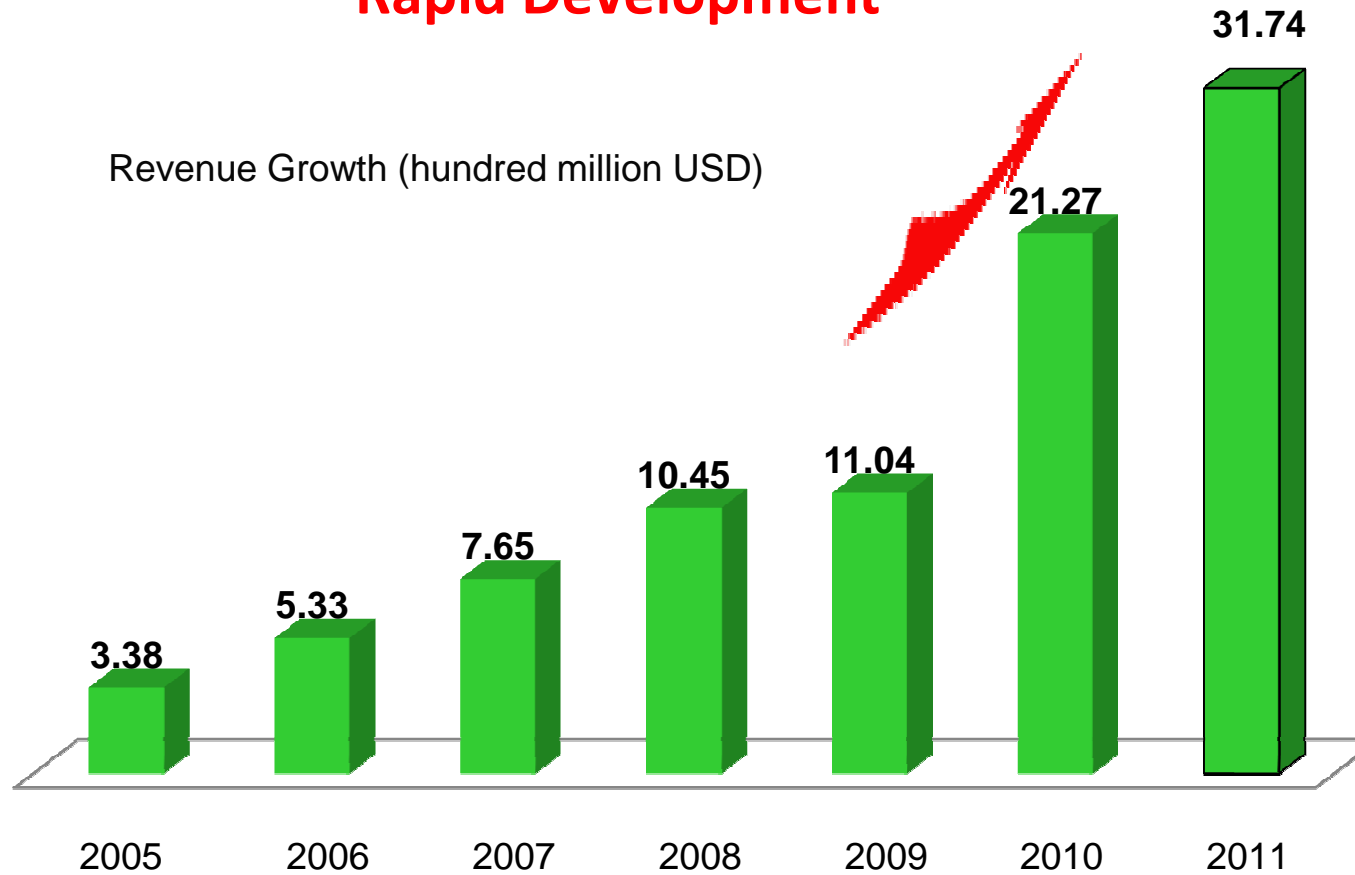

International Cooperation---Komatsu Shantui

Shantui Introduced first Komatsu Bulldozer in 1981. Technical & Managerial cooperation between these two companies has been lasted over 30 years.

In 1995, Komatsu Shantui Construction Machinery Co., Ltd. was founded for hydraulic excavator manufacturing in Jining, China. The investors are Shantui, Komatsu, Sumitomo, Itochu & Marubeni with registered capital 21 million USD.

Up to now, Komatsu Shantui has become an excellent example for international cooperation. It creates benefit & return for investors & society.



SHANTUI

Shantui Forklift Overseas Market Development

Responsibility Communication Inclusiveness



Market Globalization Career

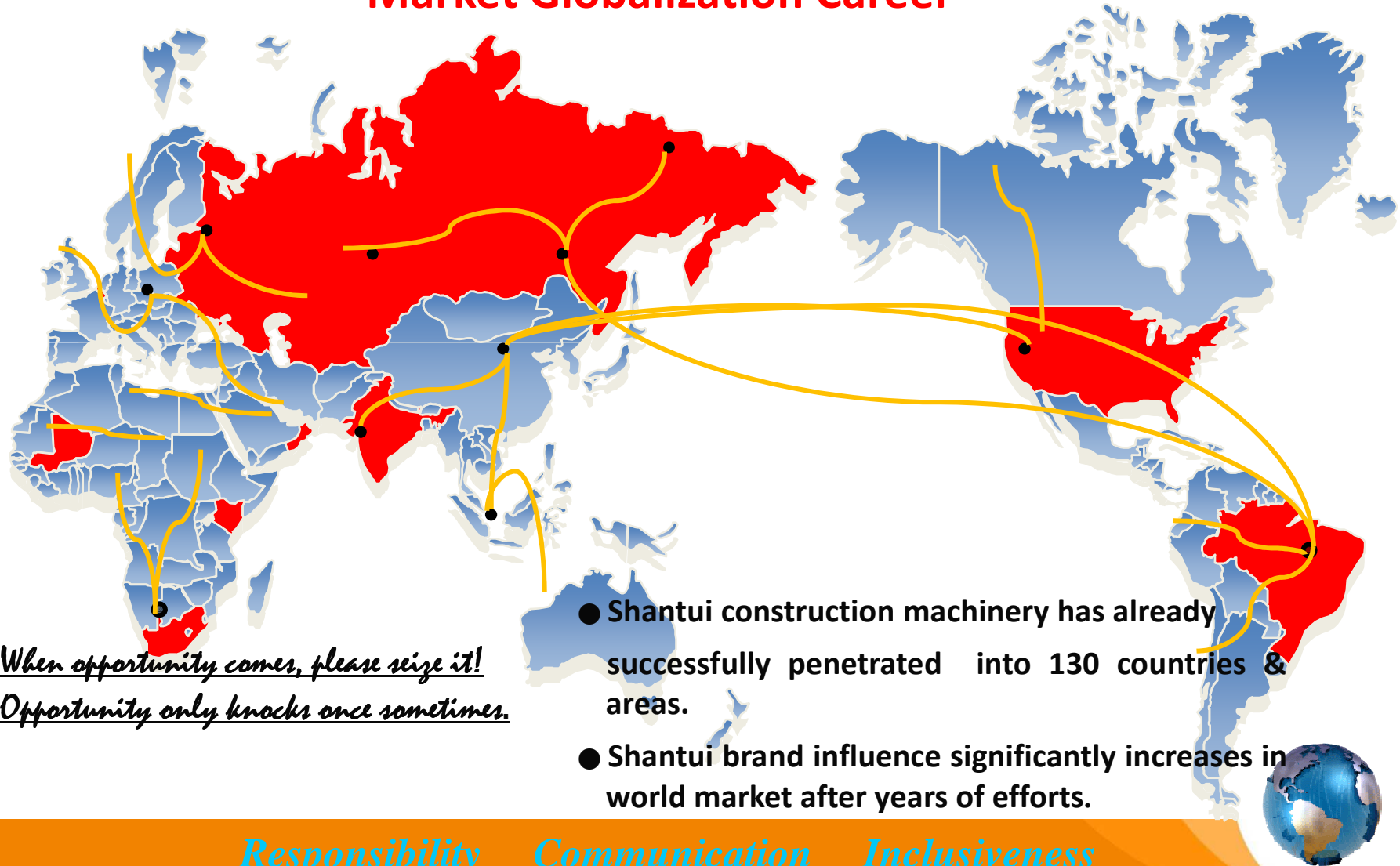

*When opportunity comes, please seize it!
Opportunity only knocks once sometimes.*

- Shantui construction machinery has already successfully penetrated into 130 countries & areas.
- Shantui brand influence significantly increases in world market after years of efforts.

Responsibility Communication Inclusiveness

Plan & Policy

- ◇ In December, 2011, Shantui signed its first overseas distribution agreement with its Turkish Distributor, which heralds a rapid overseas market expansion



- ◇ To develop 40~50 distributors in major markets within next three years
- ◇ Sustainable relationship with long term cooperation
- ◇ Keep more profit margin for partners to boast market share increase rapidly



SHANTUI

THANKS!

WELCOME TO JOIN SHANTUI GLOBAL DISTRIBUTION NETWORK



www.shantuimachinery.com
Shandong Shantui Machinery Co., Ltd.